



KPT-93-3

TRIPLE DOOR PIZZA PREP TABLE

All-stainless steel construction, heavy-duty refrigeration system that delivers reliable and efficient cold storage with superior quality.



KEY FEATURES



• **Eco-Friendly Refrigerant**

Environmentally friendly R290 hydrocarbon refrigerant has low Global Warming Potential (GWP). Meets all USA, California & Canada refrigerant & energy standards.



• **Digital Control**

Digital temperature controls and display with automatic defrost system.



• **High Power Reliable Refrigeration System**

Fast pull down, optimal internal air circulation and reliable refrigeration, maintaining cooler temperatures for food preservation.



• **Durable, Self-contained System**

Stainless steel exterior and interior, coated evaporator coil and oversized side-mounted compressor



Signature **40/80 Warranty**
40 months parts and labor
80 months on compressor (part only)





KPT-93-3

TRIPLE DOOR

PIZZA PREP TABLE

PRODUCT VIEWS

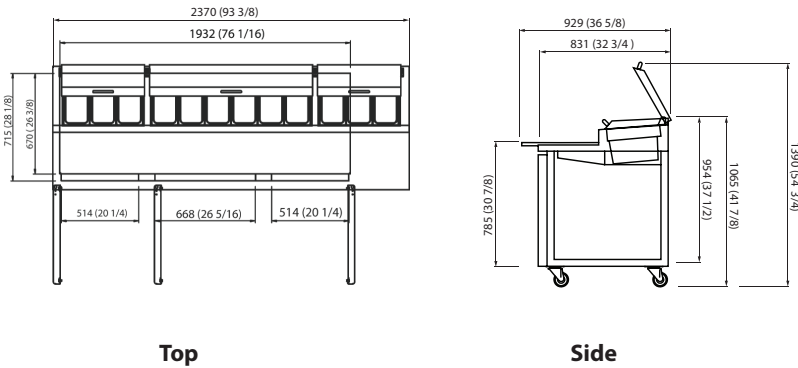

Top

Side

ADDITIONAL FEATURES



Removable, easy to clean 18.9" deep cutting board



Equipped with 6 4" polycarbonate food pans (can accommodate 6" pans of left side of unit - note: right side can only accommodate 4" pans due to air circulation)



Heavy-duty 5" castors (2 with brakes)



Self-closing doors with stay open feature



Foamed-in-place high-density CFC-free polyurethane insulation



Tight-sealing magnetic vinyl gaskets



1" thick insulated lid

Specifications subject to change without notice.

TECHNICAL SPECIFICATIONS

| Exterior Dimensions | | Interior Dimensions | |
|--------------------------|-------------------|---------------------|------------------------------|
| W: | 72.4" (1839 mm) | W: | 67.5" (1715 mm) |
| D: | 36.625" (929 mm) | D: | 26.375" (670 mm) |
| H: | 41.875" (1065 mm) | H: | 23.4" (594 mm) |
| Interior Capacity | | | |
| 20.2 Cu Ft 473 L | | | |
| Doors | Material | Shelves | Pan Capacity (Type Included) |
| 3 | Stainless Steel | 6 | 12 (1/3 x 4") |
| Exterior Material | | Stainless Steel | |
| Interior Material | | Stainless Steel | |

REFRIGERATION PERFORMANCE

| | |
|-----------------------------------|----------------------------|
| Refrigerant | R290 |
| Compressor Power | 1/4 HP |
| Thermostat default setting | 33°F (0.5°C) to 39°F (4°C) |

ELECTRICAL

| | | | |
|---------------------|-----------|-------------|------|
| Power Supply | 115V/60Hz | Amps | 3.5A |
| Plug Type | | NEMA 5-15P | |

LOGISTICS

| Unit Weight | Shipping Dimensions | |
|------------------------|---------------------|-----------------|
| 452 lb (205 kg) | W: | 48.4" (1229 mm) |
| Shipping Weight | D: | 37" (940 mm) |
| 492 lb (223 kg) | H: | 44.3" (1125 mm) |