

Project Name:	
Model Specified:	
Location:	
Item No:	Quantity :
AIA #:	SIS # :

Model: GPZ166A-ETL
Pizza prep-table refrigerator

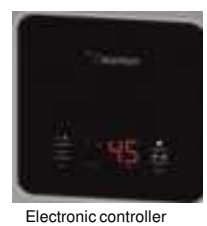

Magnetic removable gasket without tools



Internal bottom made in S/S with stamped rounded corners to facilitate the cleaning procedures.



Plastic pans

Standard Model Features:

Is designed with enduring quality that will improve the efficiency and production of your restaurant. Constructed with stainless steel AISI 304 interior & exterior.

- **REFRIGERATION SYSTEM**
 - Factory engineered, self-contained, capillary tube system using environmentally friendly (HCFC free) R452a refrigerant.
 - Temperature Range, getting the best in food preservation:
 - Coolers adjustable from (28 to 46°F).
 - Ventilated - autodefrost -auto evaporation - front -breathing
 - Evaporator coil & condenser balanced for low power consumption - holding the widest temperature range in its class.
 - Sealed, cast iron, self-lubricating evaporator fan motor(s) and larger fan blades with a more efficient low velocity, high volume airflow design.

- **CABINET ARCHITECTURE**
 - All made in stainless steel AISI 304
 - Higher insulation rates thanks to high-tech environmentally friendly CFC free, Cyclopentane foaming keeping insulation properties longer than other foams. 5% of energy consumption savings guarantee if compared to other CFC free foams.
 - No . 4 casters (2 with break)
 - Power cord and plug supplied
 - Electronic digital temperatur controller
 - Insulation : Ciclopentane High density foamed in place environmentally friendly.
- Kyoto Protocol Compliant:
 ODP = 0 (Ozone Depletion Potential)
 GWP = 5 (Global Warming Potential) polyurethane keeps energy costs low.

- **DOORS**
 Nr. 2 doors , gasket of one piece construction, removable without tools for ease of cleaning.

- **SHELVING**
 Nr. 1 Epoxy coated wire shelf standard, installed per full door section 460x660mm (18"x26")

- **PANS CONFIGURATION**
 Nr. 8 GN1/3 + nr. 1 GN2/8 (not included)

- **MODEL FEATURES**
 - Electronic digital temperatur controller with alarms.
 - Evaporator is epoxy coated to eliminate the potential of corrosion.
 - Unit completely pre-wired at factory and ready for final connection to a dedicated outlet.
- Cord and plug set included: Voltages:
 115V/60Hz/1 phase

Options and Accessories :

Upcharge and lead times may apply

- Feet

Specification may change without prior notice

Model	Capacity Lt / ft³	Ambient temp. °C/°F	Cabinet / Packing Dimensions			Voltage	Amp	Shipping Weight
GPZ166A-ETL	175 / 6,18	40° / 104°	mm / inches			115/60/1	5 + 1,5	350kg/772Lbs
Temp. °C / °F	Door	Absorbed Power W	W	D	H	Plug	"L" Guide	Gas
-2° , 8° C 28° , 46° F	2	400 + 130	166 (cm) 65 5/16"	80 (cm) 31 15/32"	147,5(cm) 58 1/16"	NEMA 5-15P	8 pairs	R452A
			178(cm) 70 3/32"	91 (cm) 35 13/16"	131(cm) 51 9/16"			



Model specifications:

Dimensional data		Electrical data	
Capacity	6,18	Voltage (int'l)	115V /60Hz / 1 Ph
Width, Overall (in.)	65 5/16	Absorbed Pow	400/130 W
Depth, Overall (in.)	31 15/32	Amps	5/1,5 A
Depth (in.) (doors open 90°)	57	Cord / Plug	NEMA -5-15P
Height, Overall (in.) (incl. feet or casters)	58 1/16	Refrigerant data	
No. of doors	2	Condensing U	1/4
No. of shelves	2	Capacity (BTU)	3000
Shelf Area (sq.ft.)	3,26	Shipping data	
Max load shelf (lbs)	105	Height - Crate	63
Temp. Range (°F)	28° , 46°	Width - Crate	71
Ambient temp. (°F)	104°	Depth -Crated	50 13/32
		Weight (lbs)	772

Model Plan Views

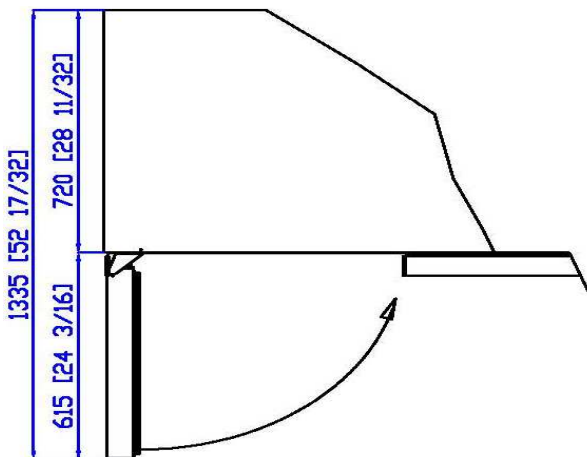
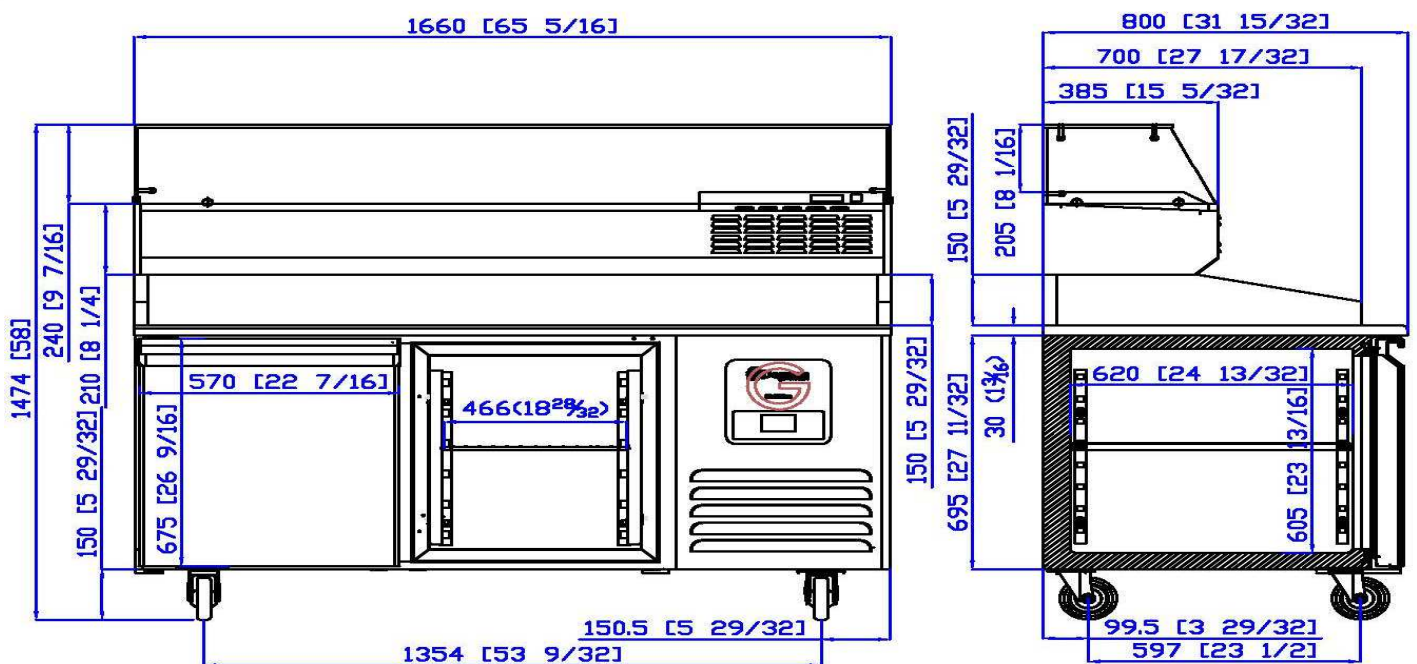

NOT INCLUDED

