

E71 GTi

FAEMA
THE ART MACHINE

MODEL:	ITEM:
FAEMA E71 GTi Autosteam White 2grp	F01-UB23611BTG9BA
FAEMA E71 GTi Autosteam Black 2grp	F01-UB23619BTG9BA
FAEMA E71 GTi Autosteam White 3grp	F01-UB33611BTG9BA
FAEMA E71 GTi 3grp Black	F01-UB33619BT999A
FAEMA E71 GTi Autosteam Black 3grp	F01-UB33619BTG9BA

Date:

Project:

Location:

Energy-saving features with
40% higher daily energy savings than standard models.

E71 *Gti*



FEATURES



DUAL DELIVERY MANAGEMENT



SMART BOILER



GTI THERMAL SYSTEM



AUTOSTEAM COLD TOUCH



RUVECO TECK



CONNECTIVITY



Designed for all those who seek perfection and superior quality with each sip and with every cup of coffee.

The FAEMA E71 has a new hydraulic circuit with GTi infusion control system that guarantees both high-precision infusion and perfect coffee brew time regulation. The GTi system allows you to control the duration of every extraction stage and to set the temperature of each grouphead independently. Brewing time duration can be set on the touchscreen or manually with the lever.

DESIGNED FOR BARISTA

The FAEMA E71 features innovative ergonomic solutions, including the cold touch steam wand, the new soft touch open-spout portafilters with a specially developed grip angle. An illuminated work area, a flush system to eliminate coffee residues from the previous delivery and a steam wand purge function to eliminate any condensation created during medium-long time intervals between steam bursts. Releasing the lever enables it to return automatically to the starting position.



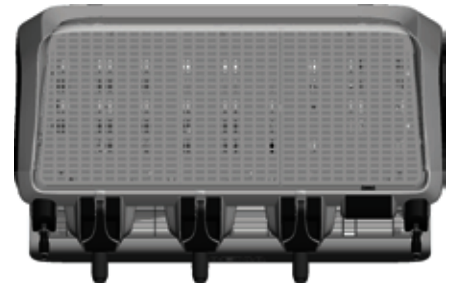
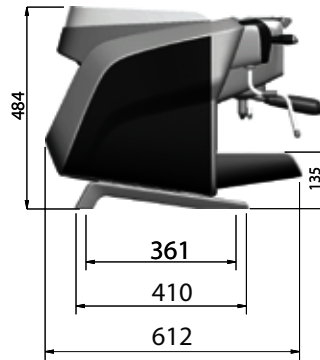
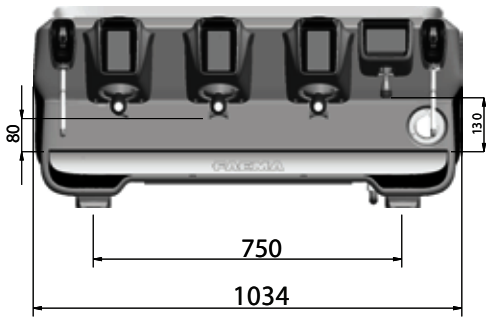

AVAILABLE IN TALL CUP VERSION.

	E71 GTI	
	A2	A3
Features		
Steam wands	2 / 1 + AS Milk4	2 / 1 + AS Milk4
Hot water wands + selections	1 + 3	1 + 3
Boiler capacity (L)	7	7
Independent boilers/capacity (L)	2/ 0.6	3/0.6
Electric cup warmer (3-temp settings)	✓	✓
Technical Information		
Dimensions: Width x Depth x Height (mm)	794 x 612 x 484	1034 x 612 x 484
Weight (kg)	71	90
Power at	220-240V~60Hz (W) 220-240V3~60Hz (W)	5300 - 7000 6200 - 7400
		7500 - 8800 6500 - 8500

Water & Drain Line Requirements

Cold Water Line:

3/8" dedicated cold water line with shut-off valve, compression fitting and back flow preventer.

Water Flow:

Minimum incoming water flow rate of 35 GPH and maximum line pressure 70PSI/ 5 Bar. Should flow pressure exceed 70 PSI a pressure reducer is necessary.

Drain:

Open gravity drain of minimum 1.25" ID size for hose, within 4 feet of machine.

Access Hole:

There must be a 2 1/2" access hole underneath the machine to connect the water, drain and power supply.



E71 *Gti*

Euro-Milan Distributing reserves the right to modify the characteristics of the products illustrated in this publication without prior notice for misprints and other errors. There may be colour deviations due to the printing process.

A2- Group

A3- Group

Receptacle



NEMA L6-30R

Receptacle



NEMA 6-50R