

PLUS 600 (COUNTER TOP) – 11L



BERTO'S[®]
the best catering equipment

MODEL: _____ ITEM: _____
Bertos Counter Top Pasta Cooker 11 Lt B06-E6CP3B

Date: _____
Project: _____
Location: _____

Pasta Cooker-
Cooking for the next
generation of chefs.



FEATURES



11 L Basin Capacity



Boiling Time | 20 min



**Perfect insulation
and precise energy
supply.**

Energy saving and reduced
environmental impact.

Between form and substance

Our cookers stand out for their contemporary design, inspired by elegant essential shapes and lines, that are functional and combine design and ergonomics for the perfect balance between modern form and substance.

Cookers built and tested to last

Berto's products are not afraid of the passing years, only the best steel and expertise of their technicians are the ingredients that enable them to consider time as an ally.



Innovation is the soul of BERTO'S, and we are constantly working with passion to create the best solutions of the future.





E	Electric Connection	V 220-240 ~	kw 3,5
C	Water Charging	R 3/8 UNI ISO 7/1	

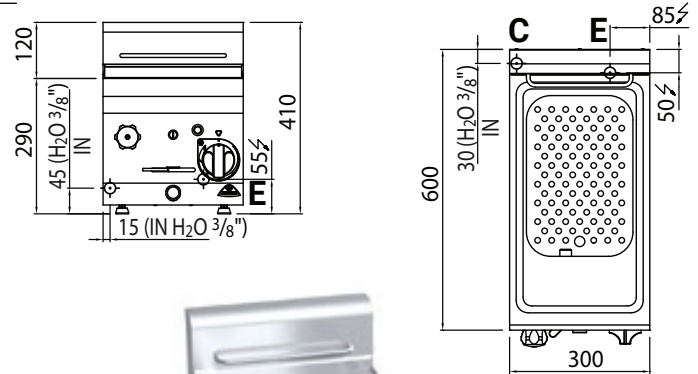

FUNCTIONAL FEATURES

Worktop in AISI 304 stainless steel.

Pressed basin with large rounded edges completely made in AISI 316 stainless steel.

Water circulation guaranteed by a drilled bottom that ensures the baskets kept away from the basin base and protects the heating elements positioned in the basin.

Spherical draining tap with front bayonet connection controlled by a heat-proof handle.

Adjustable feet.

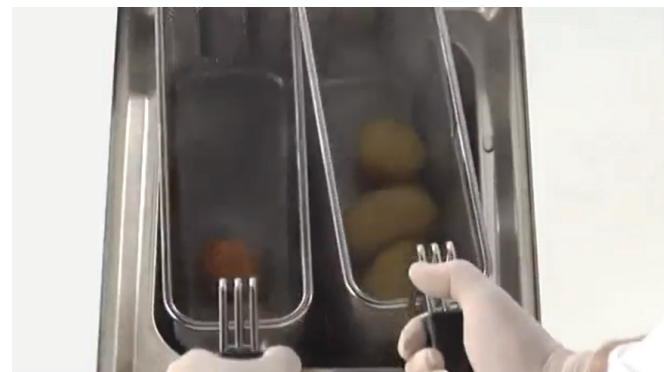

Technical Details	
Basin Capacity (L)	11
Dimensions: Width x Depth x Height (mm) - Basin	340 x 225 x 210
Dimensions: Width x Depth x Height (mm)	340 x 350 x 200
Weight (kg)	18
Power (kw)	3.5
Voltage (v)	220-240V/60Hz

OPTIONAL ITEMS

- 1 basket
- kit of 2 twin-baskets
- basket lid



Euro-Milan Distributing reserves the right to modify the characteristics of the products illustrated in this publication without prior notice for misprints and other errors. There may be colour deviations due to the printing process.

